

1. PHYSICAL CHARACTERISTICS (mm):

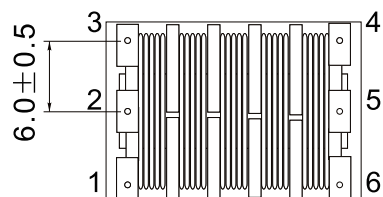

2. ELECTRICAL SCHEMATIC:

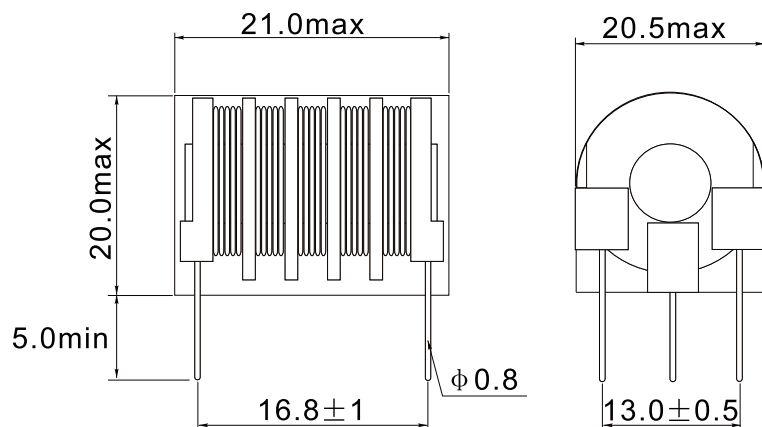
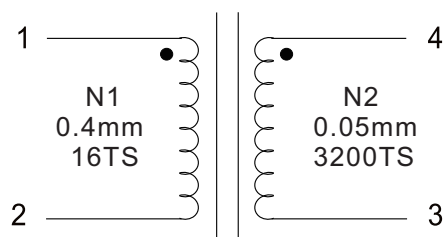

3. ELECTRICAL SPECIFICATIONS:

Turns ratio: 200:1

Inductance(1-2): 20uH±15%@1.0KHz,0.1V

Inductance(4-3): 330mH±15%@1.0KHz,0.1V

DCR(1-2): 0.093Ω±10%

DCR(4-3): 1240Ω±10%

4. MATERIALS LIST:

No.	Item	Materials	UL No.	Suppliers
1	Epoxy	102GF30UVW Transparent	E243880	Beijing hanlun industrial plastics Co.,Ltd
2	Bobbin	PBT4130 White	F48285CM	Yun cheng plasti CO.,LTD
3	Wire	2UEW	E194766	Xuzhou shengbao industry CO.,LTD
4	Core	R6X15	E320847	

Note:

1. RoHS Compliant
2. Flammability: UL94V-0
3. ASTM oxygen index: >28%
4. Temp 20°C, 48%RH



MAGASON-TECH

E-mail: sales@magason-tech.com Web: www.magason-tech.com TEL: +86-29-86364084

NAME		High voltage transformers	
CUSTOMER P/N		Date	2018-08-05
MAGASON P/N	HTR0615-200TS	Rev. A1	Page 1/1
Drawn. by	Checked. by	Approve. by	